

Hyd. Circuit - JumboZ-500M

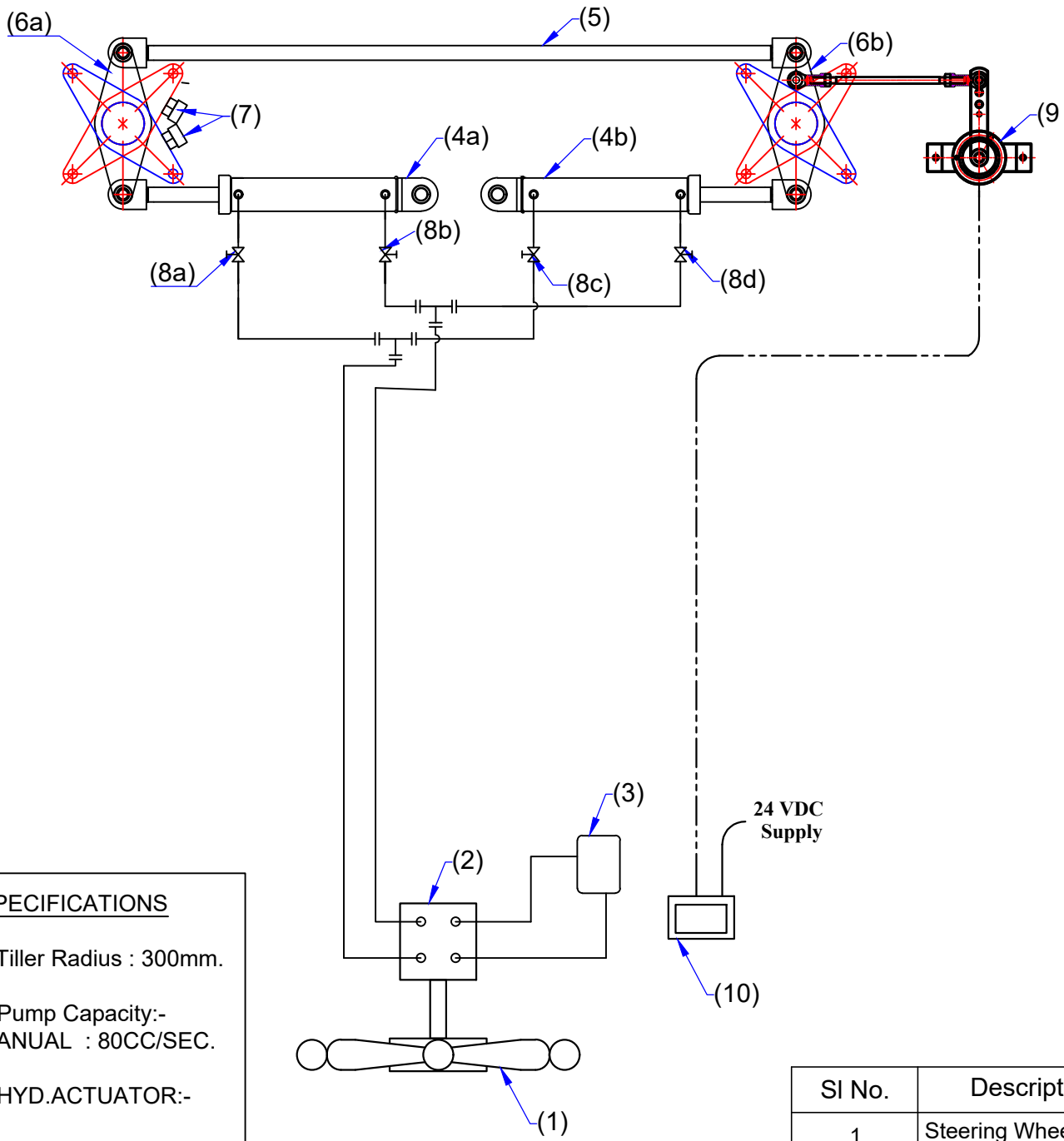

SPECIFICATIONS

1. Tiller Radius : 300mm.
2. Pump Capacity:-
MANUAL : 80CC/SEC.
3. HYD. ACTUATOR:-
BORE : 55MM.
STROKE : 440MM.
4. PIPE :-
OD -16MM.
ID -12MM.

OPERATING PARAMETERS

Torque rating - 7000Nm. at 0° Rudder Angle and 5892 Nm., at 35° Rudder Angle, Considering 2 Hydraulic Actuators Connected to a Rudder through Tiller Arm of 300mm. Radius. Working Pressure 70Kg./cm².

SI No.	Description
1	Steering Wheel
2	Manual Helm pump
3	Oil Reservoir
4a,4b	Hyd. Actuator JZ-500 Connection Rod (Yard Supply)
5	
6a,6b	Tiller Arm Mechanical Stopper (Yard Supply)
7	
8a,8b,8c,8d	Isolation Valves
9	Rudder Angle Sensor Rudder Angle Indicator
10	



MAC ♦ N ♦ HOM SYSTEMS
KOCHI - 20

DESIGNATION

Hydro. Circuit of JumboZ-500 Manual Steering

DWG. No.

MHS-1551A

DATE

05.05.2023

A

B

C

D

E

F

G

H